



SPP

*Southwest
Power Pool*

***Facility Study
For
Generation Interconnection
Request
GEN-2010-029***

***SPP Generation
Interconnection***

(#GEN-2010-029)

January 2012

Summary

Sunflower Electric Power Corporation (SUNC) performed a detailed Facility Study at the request of Southwest Power Pool (SPP) for Generation Interconnection request GEN-2010-029. The request for interconnection was placed with SPP in accordance with SPP's Open Access Transmission Tariff, which covers new generation interconnections on SPP's transmission system.

Interconnection Customer Interconnection Facilities

The Interconnection Customer will be responsible for the 345 kV transmission line from its wind turbine Collector Substation to the Point of Interconnection (POI), the Spearville 345kV substation located in Ford County. In addition, the customer will be responsible for reactive power compensation equipment to maintain 95% lagging (providing vars) and 95% leading (absorbing vars) power factor at the point of interconnection.

Transmission Owner Interconnection Facilities and Non-Shared Network Upgrades

Per the following Facility Study, the Interconnection Customer is responsible for **\$8,000,000** of Transmission Owner Interconnection Facilities and non-shared network upgrades.

Shared Network Upgrades

The interconnection customer was studied within the DISIS-2011-001 Impact Study. At this time, the Interconnection Customer is allocated the following cost for shared network upgrades:

Upgrade Description	Allocated Cost	Total Cost
Benton – Wichita 345kV Upgrade line terminal equipment to 2000 Amps (Construction by Westar)	\$272,762.96	\$1,183,000
Reno – Circle 345kV Dbl CKT Build new transmission line between Reno and Circle. (Construction by Westar)	\$11,170,005.48	\$39,408,253
Spearville – Mullergren 345kV DBL CKT Build new 345kV transmission line from Spearville to Mullergren. Includes substation work at Spearville. (Construction by Sunflower)	\$30,542,780.67	\$107,756,225.40
Mullergren – Circle 345kV DBL CKT. Build new 345kV transmission line from Mullergren to Circle. Includes substation work at Mullergren. (Construction by Sunflower)	\$36,916,725.94	\$130,243,774.60
Tatonga – Mathewson Build second 345kV circuit from Tatonga – Mathewson.	\$7,508,127.11	\$105,965,000.00
Mathewson – Cimmaron 345kV Build new 345kV transmission line from Mathewson – Cimmaron.	\$2,422,216.71	\$29,125,118.00
Mullergren 345/230kv autotransformer	\$4,935,113.06	\$15,000,000

Total	\$93,767,731.93
--------------	------------------------

If higher queued interconnection customers withdraw from the queue, suspend or terminate their GIA, restudies will have to be conducted to determine the Interconnection Customers' allocation of shared network upgrades. All studies have been conducted on the basis of higher queued interconnection requests and the upgrades associated with those higher queued interconnection requests being placed in service.

Additional Required Network Upgrades

Certain Network Upgrades that are not the cost responsibility of the Customer are required for Interconnection. These Network Upgrades include:

1. Hitchland - Woodward 345kV double circuit transmission line,
2. Medicine Lodge – Woodward 345kV double circuit transmission line,
3. Spearville-Clark-Medicine Lodge 345kV double circuit 345kV transmission line
4. Medicine Lodge – Wichita 345kV double circuit 345kV transmission line

These network upgrades are not schedule to be in service until December 31, 2014. Depending upon the status of higher or equally queued customers, the Interconnection Customer's in service date may be delayed until the in service date of these Network Upgrades.

Executive Summary

<OMITTED TEXT> (Customer) has requested a Facility Study under the Southwest Power Pool Open Access Transmission Tariff (OATT) for interconnecting a 450 MW wind powered generation facility in Ford County, Kansas to the transmission system of Sunflower Electric Power Corporation (SUNC). The wind powered generation facility studied is comprised of two hundred and fifty two (252) Vestas 1.8 MW wind turbines. The wind powered generation facility will interconnect into the planned Spearville 345 kV Substation.

SUNC will add a 345kV breaker and half leg to the ring bus at the planned Spearville substation and terminate the GEN-2010-029 wind farm. The Interconnection Customer's non shared network upgrades and interconnection facilities are estimated at \$8,000,000.

The Customer will be responsible for reactive power compensation equipment to maintain 95% lagging (providing vars) and 95% leading (absorbing vars) power factor at the point of interconnection.

1. Introduction

<OMITTED TEXT> (Customer) has requested a Facility Study under the Southwest Power Pool Open Access Transmission Tariff (OATT) for interconnecting a 450 MW wind powered generation facility in Ford County, Kansas to the transmission system of Sunflower Electric Power Corporation (SUNC). The wind powered generation facility studied is comprised of two hundred and fifty two (252) Vestas 1.8 MW wind turbines. The wind powered generation facility will interconnect into the planned Spearville 345kV Substation.

2. Interconnection Facilities and Network Upgrades

The cost for the Interconnection Facilities and Network Upgrades is listed below in Table 1. The one-line diagram is shown in Figure 1.

Table 1: Required Interconnection Facilities and Non Shared Network Upgrades

Project	Description	Estimated Cost
1	SUNC-add 345kV breaker and half leg to the ring bus at the planned Speaville substation, and terminate GEN-2010-029 wind farm.	\$8,000,000
	Total:	\$8,000,000

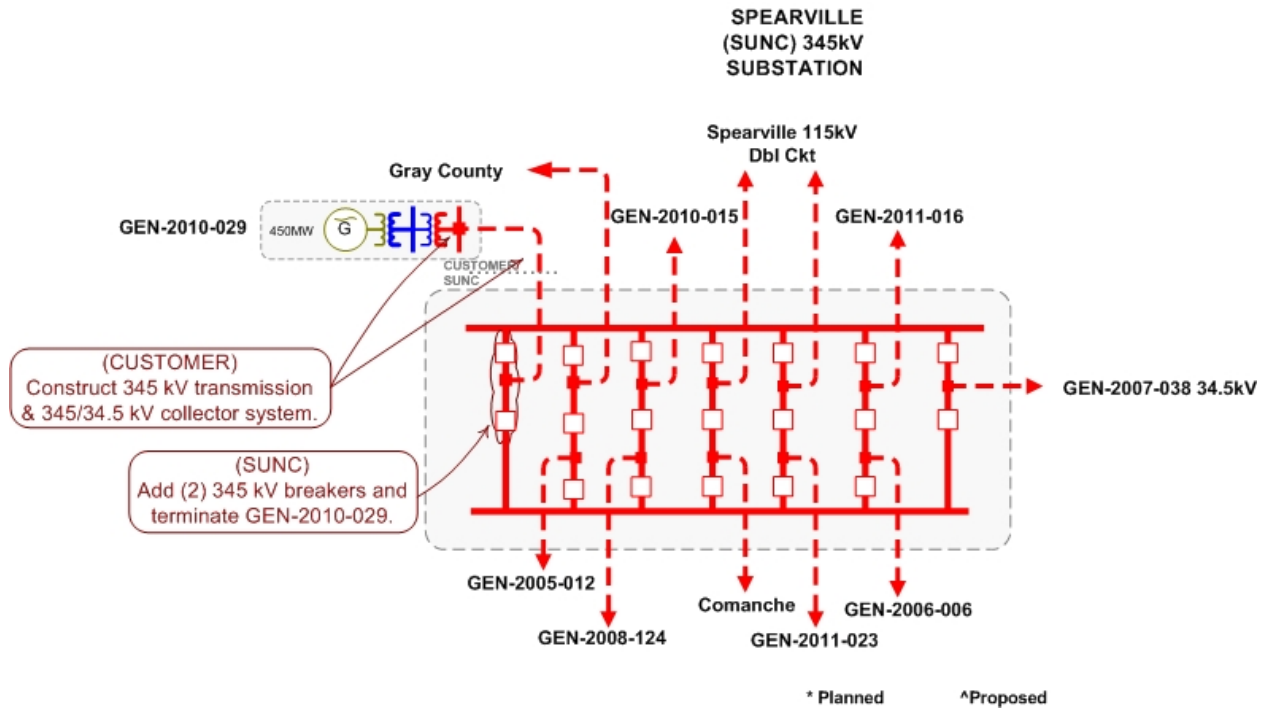

Figure 1. Interconnection Configuration for GEN-2010-029

2.1. Customer Facilities – The Customer will be responsible for its Generating Facility and its 345/34.5 kV substation that will contain its 345/34.5 kV transformer(s) and wind turbine collector feeders. In addition, the Customer will be required to install the following equipment in its facilities.

2.1.1. Reactive Power Equipment – The Customer will be responsible for reactive power compensation equipment to maintain 95% lagging (providing vars) and 95% leading (absorbing vars) power factor at the point of interconnection. Any capacitor banks installed by the Interconnection Customer shall not cause voltage distortion in accordance with Article 9.7.4 of the standard SPP Generation Interconnection Agreement.

3. Conclusion

The Interconnection Customer’s interconnection facilities are estimated at \$8,000,000.